

Model year 2007 SUN ODYSSEY SUN FAST

Sun Odyssey 29.2

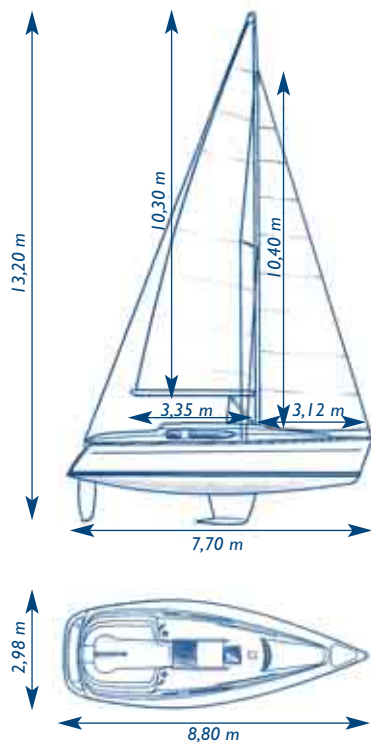

Sun Odyssey 32i

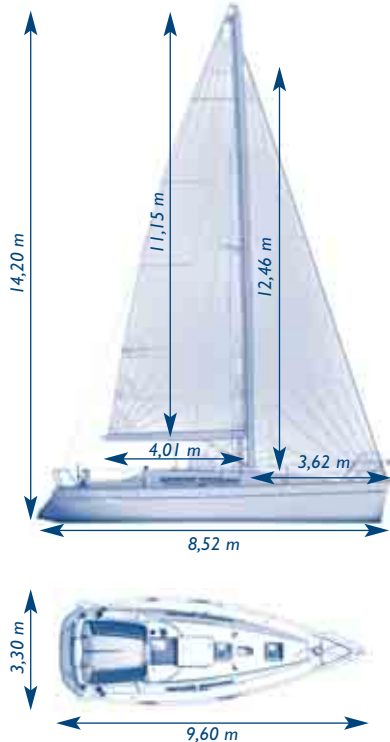

Sun Fast 32i

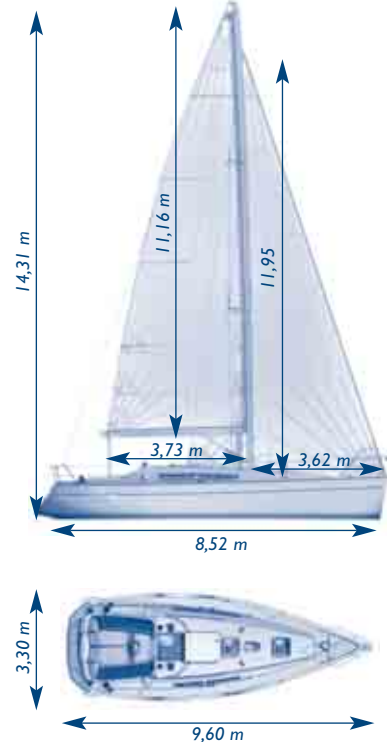

Certification conform with CE regulation.

	SO 29.2	SO 32i	SF 32i	
Specifications	Overall length	8,80 m	9,60 m	9,60 m
	Hull length	8,50 m	9,45 m	9,45 m
	Waterline length	7,70 m	8,52 m	8,52 m
	Beam	2,98 m	3,30 m	3,30 m
	Displacement <i>light load with deep draft keel</i>	2750 kg	4300 kg	4190 kg
	Standard draft <i>cast iron fin keel with elongated bulb and exterior epoxy barrier coat</i>	1,40 m	2,00 m	2,00 m
	Standard keel weight	1010 kg	1130 kg	1130 kg
	Shoal draft <i>cast iron fin keel with elongated bulb and exterior epoxy barrier coat</i>	-	1,50 m	-
	Lifting keel weight	-	1370 kg	-
	Lifting keel version <i>galvanised centreboard located in an external iron keel fin</i>	0,75-1,60 m	0,86-1,84 m	-
	Lifting keel weight	1240 kg	1665 kg	-
	CE category	B6/C8	B6/C8	B6/C8
	Architect/designer	J. Farroux	P. Briand	P. Briand
	Water capacity	100 L	170 L	170 L
Fuel <i>rotomolded tank located under aft berth with deck fill</i>	45 L	70 L	70 L	
Holding tank <i>rotomolded tank located in head compartment with valve for overboard discharge via gravity and deck fitting for pump out</i>	50 L	50 L	50 L	
Fridge <i>fibreglass fridge compartment with vertical access</i>	45 L	120 L	120 L	
Sails	Classic mainsail <i>80% battened, polyester sailcloth, Rutgerson® stainless steel eyes and 2 reinforced reef points with auto reef</i>	20 m ²	25,1 m ²	*25,5 m ²
	Furling genoa <i>125% high-tenacity Dacron cloth, UV luff protection, Rutgerson® stainless steel eyes</i>	20 m ²	25,2 m ²	*28,5 m ²
	Furling mainsail (optional) <i>polyester sailcloth, UV luff protection, Rutgerson® stainless steel eyes</i>	17,4 m ²	21,9 m ²	-
	Spinnaker <i>optimal size for boat (not available from Jeanneau)</i>	53 m ²	62,1 m ²	*67 m ²
	Total sail area <i>for standard mast and sails</i>	40 m ²	50,3 m ²	*54 m ²

*The Sun Fast 32i is delivered without sails

■ Standard □ Option - Non disponible

	SO 29.2	SO 32i	SF 32i	
Sail Handling	Lazy bag in Sunbrella® Captain Navy fabric with integrated lazy jacks	■	■	-
	Winches 2 x Harken 32.2 self-tailing winches for genoa and halyards	■	-	-
	Genoa winches 2 x Harken 32.2 self-tailing winches	-	■	-
	Coachroof winch 1 x Harken 16.1 self-tailing winch	-	■	-
	Coachroof winches 2 x Harken 32.2 self-tailing winch	-	-	■
	Genoa winches 2 x Harken 40.2 self-tailing winches	-	-	■
	Genoa tracks adjustable lead cars	■	■	-
	Harken turning blocks for genoa sheets	■	■	■
	Harken genoa tracks ball-bearing cars with control lines lead aft to cockpit	-	-	■
	Winch handle 1 x Harken handle with ball-bearing grip	■	-	-
	Winch handles 2 x Harken handles with ball-bearing grip	-	■	-
	Winch handles 3 x Harken handles with ball-bearing grip	-	-	■
	Line jammers Spinlock, on coachroof	■	■	■
	Mainsheet attached to padeye in cockpit for easy use and can be removed when in port	■	-	-
	Mainsheet attached to padeyes forward of companionway hatch with sheet lead back to cockpit winch	-	■	-
	Mainsheet traveller cockpit-mounted Harken traveller with ball-bearing cars	-	-	■
	Spinnaker deck hardware 3 x Spinlock jammers on coachroof, 3-sheave return block on deck, 3 padeyes on side decks	□	-	-
	Spinnaker deck hardware triple Spinlock jammer, 3-sheave return block on deck, 4 padeyes, 3 bullet leads and 2 Harken cam cleat	-	□	-
	Asymmetrical spinnaker gear halyard, 2 sheets, tack line lead forward on deck, 3 blocks	-	□	-
	Spinnaker pole aluminium	-	-	□
Symmetrical spinnaker gear halyard, 2 sheets, barber hauls, pole uphaul and downhaul and Harken blocks	-	-	■	
Symmetrical spinnaker gear halyard, 2 sheets, pole uphaul and downhaul, spinnaker pole, and necessary blocks	□	□	-	
Mast and Rigging	Classic mast aluminium with single spreaders, deck-stepped	■	■	-
	Performance classic mast aluminium with double spreaders, keel-stepped, 9/10th fractional	-	-	■
	Standing rigging discontinuous 1x19 stainless steel wire	■	■	-
	Standing rigging discontinuous Dyform® stainless steel wire	-	-	■
	Backstay fixed	■	■	-
	Backstay adjustable via a block and tackle system	-	-	■
	Genoa furler Facnor® furler with attachment to stemhead fitting and furling line lead aft to roof winch	■	■	-
	Genoa furler Facnor® racing series with removable drum, double sail slot and aerodynamic profile, mounted to stemhead fittings with short link plates to maximise sail area, furling line lead aft to roof winch	-	-	■
	Running rigging topping lift, mainsail halyard, genoa halyard, mainsheet, genoa sheets	■	■	-
	Running rigging topping lift, mainsail halyard, genoa halyard, mainsheet with fine tune, genoa sheets	-	-	■
	Boom vang block and tackle system	■	■	-
	Rigid boom vang with gas cylinder and control line lead aft to the cockpit	-	-	■
	Anchor and steaming light	■	■	■
	Windex 15 wind indicator for masthead	□	□	□
Cockpit & Deck Storage	Wood inlay on cockpit bench seating	□	■	■
	Wood cockpit floor inlay	□	□	-
	Cockpit locker 1 large cockpit locker to starboard under bench seat with integrated gas locker	■	■	■
	Cockpit table removable on aluminium base	□	□	-
	Cockpit table folding table mounted on pedestal (when wheel steering option is ordered)	□	□	-
	Tiller varnished wood tiller with extension handle, folds out of the way to keep cockpit clear	■	■	■
	Wheel leather-covered steering wheel mounted on steering pedestal with grabrail and pod for instrumentation	□	□	-
	Compass bulkhead-mounted (included in pedestal steering option on SO29.2)	□	■	■
	Transom seat folding seat for easy access to the transom	■	■	■
	Transom rubrail	■	■	■
	Engine controls throttle and engine control panel, warning lights, ignition protected by a plexiglass panel	■	■	■
	Swim ladder stainless steel folding ladder mounted on transom step	■	■	■
	Cockpit shower retractable cold water shower with tap	□	-	-
	Cockpit shower retractable hot and cold water shower with tap	-	□	□
	Cockpit cushions Sunbrella® Captain Navy cushions for seating area with attachment clips	□	□	-
	Cockpit sun awning white sun awning for cockpit	□	-	-
	Cockpit sprayhood wide Sunbrella® Captain Navy with vinyl windscreen	□	□	-
	Cockpit sprayhood wide Sunbrella® Dune with vinyl windscreen	-	-	□
	Anchor locker forward, room for anchor and tackle	■	■	■

■ Standard □ Option - Not available

	SO 29.2	SO 32i	SF 32i	
Deck Hardware	Bow pulpit stainless steel, navigation lights and integrated wiring for lights	■	■	■
	Bow pulpit open, stainless steel with navigation lights and integrated wiring for lights	-	□	□
	Stern pulpits stainless steel with buoy bracket	■	■	■
	Outboard engine bracket mounted on stern pulpit	□	□	-
	Windlass mechanical windlass, vertical	-	-	□
	Windlass Quick 1000W combination rope 14mm and chain 8mm, vertical-mounted in the anchor locker, hand-held remote, manual handle	-	□	□
	Anchor roller single roller	■	■	■
	Anchoring kit fluke anchor 12kg with 18 meters of 8mm chain and 27 meters of 14mm line	□	-	-
	Anchoring kit fluke anchor 14kg with 21 meters of 8mm chain and 32 meters of 14mm line	-	□	□
	Lifelines double level of stainless steel lifelines with PVC coating, stainless steel stanchions	■	■	■
	Toerail aluminium toerail profile with 4 integrated chocks and drainage for side deck	■	■	■
	Cleats 4 x aluminium mooring cleats forward and aft	■	■	■
	Mooring kit 6 fenders and 3 docklines	□	□	□
Handrails sculpted, long teak handrails on coachroof for secure movement forward	-	■	■	

	SO 29.2	SO 32i	SF 32i		
Construction	Deck hand-laid fibreglass deck, ISO gelcoat surface, discontinuous balsa block coring, interior fibreglass deck counter mould	■	-	-	
	Deck Prisma Process® injected deck, ISO gelcoat surface, discontinuous balsa block coring	-	■	■	
Lights	Hull solid, hand-laid fibreglass, ISO gelcoat surface, vinyl ester resin in outer skin to protect against osmosis	■	■	■	
	Structure inner fibreglass grid, high-load zones cut out, drainage system through structure	-	■	■	
Technical features and options	Structure wood stringers glassed to the hull and encased in fibreglass, drainage system through structure	■	-	-	
	Flush mounted chromed brass ceiling lights in saloon and cabins	■	■	■	
	Wall mounted lights in saloon and reading lights in cabins	-	■	■	
	Gooseneck chart light mounted at nav station	-	■	■	
	Electrical Circuit	12v alternator output	55 A	55 A	55 A
		Battery 70 Ah for domestic bank with charge distributor/isolator	□	□	□
		Engine start/domestic battery capacity	70 Ah	70 Ah	70 Ah
		Battery switches for engine bank, positive battery switch for domestic bank (when option is fitted) and negative general cut-off switch	■	■	■
		230v shore power inlet with differential breaker, one 230v plug at nav station + 12 A Cristec charger	□	-	-
	Plumbing	230v shore power inlet with differential breaker, one 230v plug per cabin, galley and saloon + 25 A Cristec charger	-	□	□
		Pressurised water distributed through-out the boat via semi-rigid hose	■	■	■
		"Heavy-duty" water pump and accumulator tank for consistent water pressure	■	■	■
		20 litre hot water tank that is connected to engine heat exchanger	□	-	-
20 litre hot water tank that is connected to engine heat exchanger and 230v system (when 230v shorepower system fitted)		-	■	□	
Manual bilge pump in the cockpit		■	■	■	
Chromed shower faucets in washroom		■	■	■	
Engine	Shower sumps equipped with individual electric pumps with filters and on-off switches	■	■	■	
	Manual pump marine toilets	■	■	■	
	3-way valve, switch between discharge from head directly overboard or into the holding tank	□	□	□	
	Yanmar 3YM20 21 HP , 15.3Kw with heat exchanger, latest generation of environmentally friendly engines	■	■	■	
	Fully soundproofed engine compartment with engine access behind stairwell and from aft cabin	■	■	■	
	Stainless steel propeller shaft 25mm diameter and maintenance free stuffing box	■	■	■	
	Fuel/water separator	■	■	■	
	Built-in muffler, air ventilation and stainless steel exhaust fitting aft	■	■	■	
Comfort features and options	Fixed 2-blade bronze propeller	■	■	-	
	Folding 2-blade propeller	-	-	■	

Comfort features and options	Fixed hull ports x 2 in saloon with curtains	□	■	□
	Fixed hull ports x 1 in aft cabin with curtain	-	□	□
	Fixed windows along coachroof with integrated opening ports and curtains	-	■	■
	Fixed windows along coachroof with curtains	■	-	-
	Opening cockpit and roof ports with curtains	2	3	3
	Opening cockpit port into aft cabin	□	■	■
	Opening deck hatch in saloon forward-facing with curtains	■	■	■
	Opening deck hatch in forward cabin forward-facing with curtain	□	■	■
	CD/radio player in saloon with 2 speakers in saloon	□	□	□
	Cockpit speakers watertight	-	□	□
	Forced air heating 1 unit 3500 BTU Webasto® diesel heater installed in cockpit lazarette, vents in forward cabin, aft cabin and saloon	-	□	□

■ Standard □ Option - Not available

		SO 29.2	SO 32i	SF 32i	
		2C11H	2C11H	2C11H	
Interior features and options	Wood	Fine Teak® laminated panels with solid Moabi trim around galley, companionway and cabinetry, finished in satin UV stabilised varnish	■	■	■
		Laminate floorboards laminated floorboards with light-coloured lines and sealed edges	■	■	■
	Forward cabin	Forward cabin with V-berth	■	■	■
		Double berth with high-density foam mattress	2,16 x 1,51 m	2,03 x 1,60 m	2,03 x 1,60 m
		Storage locker under berth	■	■	■
		Cabinet with hanging rod	-	■	■
		Carpeted flooring	■	-	-
		Wide, bi-fold door for easy access	■	■	■
		Vinyl lining on hull with lateral wood shelf	■	■	■
	Aft cabin	Aft cabin	■	■	■
		Double berth with high-density foam mattress	2,05 x 1,85 m*	2,05 x 1,85 m	2,05 x 1,85 m
		Deep cabinet with shelves and hanging rod	■	■	■
		Carpeted flooring	■	-	-
	Head	Vinyl lining on hull with lateral wood shelf	■	■	■
		Head compartment accessible from saloon with sink, storage cabinet, clothes hook, towel holder, toilet paper holder, shower sump with electric drainage pump	■	■	■
	Navigation station	Navigation station	■	■	■
		Full-featured electrical panel with spare breakers, voltmeter and 12v plug	-	■	■
		Forward-facing navigation desk with cushioned nav seat and storage underneath	■	-	-
		Aft-facing nav station, seating on starboard bench seat	-	■	■
		Navigation desk with storage	■	■	■
Saloon	Saloon with seating, cushions and storage under seating area	■	■	■	
	Folding saloon table with fiddles	■	■	■	
	Bottle storage compartment in table	-	■	■	
	Cushion to fit over saloon table and infill piece to turn settees into berths	-	□	□	
	Wood hull lining	-	■	■	
	Upper storage cabinets	■	■	■	
	Companionway with 4 varnished wood steps	■	■	■	
Galley	Galley with laminated countertops, chrome plumbing fittings, storage cabinets and drawers	■	■	■	
	L-galley to port with round stainless steel sink, icebox and 2-burner stove	■	-	-	
	U-shaped galley to starboard with round stainless steel sink	-	■	■	
	Stainless steel grabrail in galley	-	■	■	
	12v compressor under stove with evaporator plate located in fridge compartment	□	■	■	
	gimballed 2-burner stainless steel with broiler with stainless steel protection bar	-	■	■	
	Luxury 2-burner stove with black finish, wood handle, stainless steel oven/broiler	-	□	□	
Headroom	Forward cabin	1,63 m	1,86 m	1,86 m	
	Aft cabin	1,78 m	1,81 m	1,81 m	
	Companionway	1,79 m	1,86 m	1,86 m	
	Saloon	1,75 m	1,84 m	1,84 m	
	Galley	1,75 m	1,82 m	1,82 m	

* Aft berth of the lifting keel version measures 1,85 x 1,50 m

■ Standard □ Option - Non disponible C = Cabins H = Head